

CliniLever® Single Lever Basin Mixer with Disabled Lever

Specification Data Sheet



Technical Information

- Maximum Operating temperature range: 80°C
- Min/Max Operating pressure range - 150 - 500kPa
- Inlet connection 15mm (1/2") BSP. (Flexitails)
- Inlet pressure range 150-1000kPa

Note: AS3500.1 - Maximum operating pressure at any outlet within a building

To Specify

The AS/NZS 3718 WaterMark approved sink mixer is supplied standard with a 185mm long lever handle finished in a bright chrome plate:

Code:

TM-BASCPD - Chrome Plated CliniLever® Single Lever Basin Mixer with Disabled Lever (4 Star WELS Rating)



A family
owned
Australian
business



galvinspecialised
commercial taps + fixtures

Performance Standards & Approvals

- AS/NZS 3718 – WaterMark
- WELS 4 Star 7 Litres Per Minute



Typical Dimensions

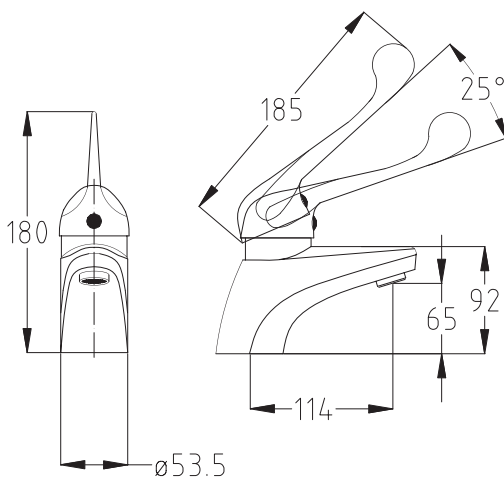

Illustrated TM-BASCPD

Features

- 40mm cartridge assembly
- Bright chrome plate finish
- Anti scald adjustable stop ring
- Optional warm/cold indicator decal
- Fitted with 7 litres per minute flow regulator
- Complies with Disabled Code

Maintenance & Cleaning

Galvin Specialised products should be cleaned with a soft damp cloth using only mild liquid detergent or soap and water. Do not use cleaning agents containing a corrosive acid, scouring agent or solvents. Do not use cream cleaners, as they are abrasive. Use of unsuitable cleaning agents may damage the surface. Any damage caused in this way will not be covered by warranty.

Regular maintenance should be carried out in accordance with the installation and troubleshooting guides provided with the product, relevant Australian Standards, local authorities and state codes.

Warranty

Galvin Specialised products are covered under our Manufacturer's Warranty at www.galvinengineering.com.au. Galvin Specialised products must be installed in accordance with the installation instructions and in accordance with AS3500 and the PCA, relevant Australian Standards and local authorities applicable to product being installed. Water and electrical supply conditions must also comply to the applicable national and/or state standards, failing to comply with these provisions may void the product warranty and affect performance of the product.

Whilst all reasonable care has been taken in compiling the information in this document, the designs, dimensions and products shown are indicative only and should not be relied upon without our prior approval. Due to our policy of continuous development, we reserve the right to alter any details of specifications or products without notice. All information, drawings, technical specifications and product designs remains the property of Galvin Engineering Pty Ltd.

410 Victoria Rd, Malaga, WA 6090
 Within Australia: **1300 514 074** Outside Australia: P: +61 (0)8 9249 5900
 F: +61 (0)8 9249 5916
sales@galvinengineering.com.au
www.galvinengineering.com.au

ABN: 78 008 719 382

PERTH | SYDNEY | MELBOURNE | BRISBANE | ADELAIDE

A business unit of

GalvinEngineering
 the mark of reliability

